



# Sunpak Models S25 & S34

Outdoor Gas Infrared Patio Heater

NOT FOR USE IN RESIDENTIAL DWELLINGS

## Installation, Operation and & Maintenance Instructions



**Installer:** Please take the time to read and understand these instructions prior to installation. Installer must provide a copy of this manual to the owner.

**Owner:** Keep this manual in a safe place in order to provide your service technician with the necessary information.

**Warning:** These instructions are intended for qualified personnel, specifically trained and experienced in the installation and repair of this type of equipment and related system components.

### **WARNING: California Proposition 65**

**IF NOT INSTALLED, OPERATED AND MAINTAINED IN ACCORDANCE WITH THE MANUFACTURER'S INSTRUCTIONS, THIS PRODUCT CAN EXPOSE YOU TO SUBSTANCES IN THE FUEL OR FROM COMBUSTION INCLUDING CARBON MONOXIDE, RESULTING IN DEATH OR SERIOUS ILLNESS AND WHICH ARE KNOWN TO THE STATE OF CALIFORNIA TO CAUSE CANCER, BIRTH DEFECTS OR REPRODUCTIVE HARM.**

**For more information go to [www.P65WARNINGS.CA.GOV](http://www.P65WARNINGS.CA.GOV)**



**Infrared Dynamics, Inc**



3830 Prospect Avenue

Yorba Linda, CA 92886

<http://sunpak.us>

For Local Distributor Listing

Call Us Toll Free (888) 317-5255

<p><b>Table of Contents</b></p> <ol style="list-style-type: none"> <li>1. Warnings</li> <li>2. Basic Operation</li> <li>3. Heater Layout and Design</li> <li>4. Installation / Service</li> <li>5. Replacement Parts</li> <li>6. Trouble Shooting Guide</li> <li>7. Warranty</li> </ol>	<p><b>Sunpak</b> heaters work like the sun projecting radiant heat down to warm your patio and guests. This heater was designed for outdoor installation; however, breezes will affect the heating efficiency, and severe weather conditions will cause the safety system to shut down the heater. <b>For your safety, you must read and understand the following warnings before continuing.</b></p>
<p> <b>WARNING</b> <span style="margin-left: 300px;"> <b>WARNING</b></span></p>	
<p>Improper installation, adjustment, alteration, service or maintenance can cause death, injury or property damage. Read and understand the installation, operating and maintenance instructions thoroughly before installing or servicing this equipment.</p>	<p>Storage of gasoline and other flammable vapors and liquids in the vicinity of this or any other appliance may result in fire or explosion. DO NOT store or use gasoline or other flammable vapors and liquids in the vicinity of this or any other appliance. Always maintain clearance to combustibles as specified.</p>
<p> <b>WARNING</b></p>	
<p><b>Not for use in residential dwellings.</b></p> <p>This heater is not approved for use in any indoor residential applications. This includes, but is not limited to, attached garage, solarium, living quarter, etc. Installation in residential indoor spaces may result in death, asphyxiation, serious injury, or property damage.</p>	<p><b>For Your Safety</b></p> <p><b>If you smell gas:</b></p> <ul style="list-style-type: none"> <li>• Shut off gas to the appliance</li> <li>• Extinguish any open flame</li> <li>• DO NOT touch any electrical switch</li> <li>• Call your gas supplier. DO NOT use any phone in your building.</li> <li>• Follow the gas supplier's instructions.</li> <li>• If you cannot reach your gas supplier call the fire department</li> </ul>

# Basic Heater Operation

## Sunpak® Heaters

Sunpak Heaters are available with two different input rates. The Model S25, rated at 25,000 Btu/Hr, allows people to be comfortable at lower mounting heights. The model S34, rated 34,000 Btu/Hr, requires greater clearance from combustible material, and it is comfortable at greater mounting heights (see page 4).

Both heaters require 24 VAC from a transformer that must be located outside of the heater. The control system is a simple on/off control with can be actuated with either a switch or a timer (supplied by installer). The electronic ignition and flame sensing require continuous power while the heater is operating.

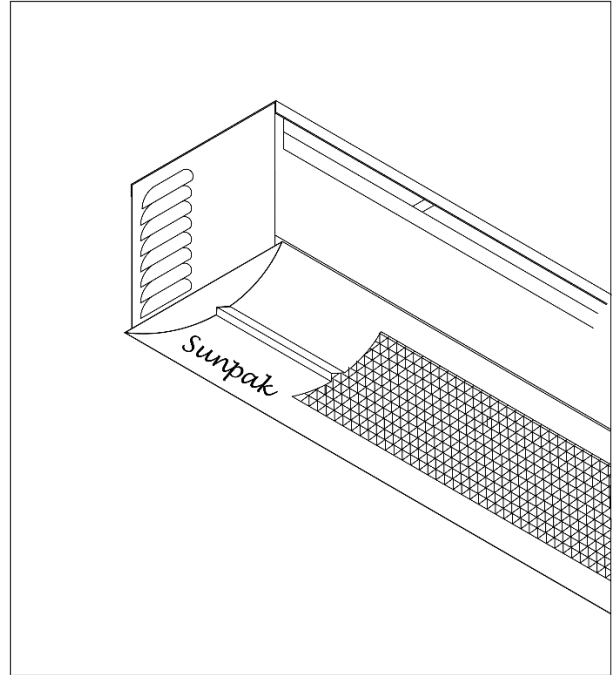

NOTE: Sunpak Heater shown with optional Face Trim

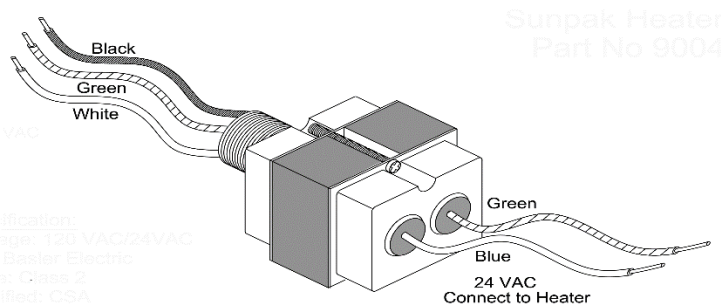

A 24 VAC Transformer with a minimum rating of 20 VA is required for each heater. Transformer should be class 2 with CSA or UL listing.

Sunpak® heaters utilize a spark ignition and electronic flame safety control. The pilot is only ON while the heater is operating. If the flame safety sensor fails to sense flame at the pilot, the heater will shut down and lockout. This may happen due to low gas pressure or a gusty wind. To restart the heater, first set the switch to OFF before turning the heater ON.

Although these heaters are designed for outdoor installation and use, it is important that switches, transformers or other operating controls be protected from the weather.

### Ventilation

Heaters are not for use in residential dwelling. Heaters used in an enclosed area require the building to have the necessary ventilation. It is required that areas above the heater be properly vented to allow for necessary combustion air and removal of combustion gases.

See page 9 for additional details.

### Definition of outdoors

1. Walls on all sides, but no overhead cover.
2. A partial enclosure which includes an overhead cover, but no more than two side walls. These side walls may be parallel, as in a breezeway, or at right angles to each other.
3. A partial enclosure which includes an overhead cover and three side walls as long as 30% of the horizontal periphery is permanently open.

## Heater Layout and Design

Sunpak® heaters were specifically designed to provide heated comfort in an outdoor environment. They have been used on outdoor patios across the United States and Canada for over 30 years. When properly integrated into a patio design, Sunpak® heaters generally increase the comfort level 5° to 10° Fahrenheit outdoors. The heating effectiveness will depend on air temperature, wind velocity and other factors. Whenever possible other local Sunpak® installations should be reviewed to determine the effectiveness for regional environment.

The environments in which Sunpak® heaters are utilized vary greatly. As an outdoor rated heater, it has passed basic wind and rain tests. This does not mean the heater cannot be damaged by the environment or when operated in very windy conditions. For this reason, it is strongly suggested that heaters be inspected and if necessary repaired annually or before each heating season.

The variable environments in which Sunpak® heaters are applied means that these general guidelines are generated by necessity and may need to be refined for local conditions. These guidelines are to be used in combination with the installation instructions.

## Patio Design Consideration

Heater placement is critical for effective and efficient patio heating. If heaters are placed too close together or mounted too low, people become uncomfortable. If heaters are placed too far apart on a breezy, wind-swept patio the patio may never get warm.

Sunpak® heaters work best if they are placed in areas of the greatest heat loss, such as the open side of a semi-protected patio area. The Sunpak® heater may be mounted at up to a 30-degree angle or face down. Note that the top clearances required from combustible material increases when heaters are at an angle. The heater must always be horizontal to the floor. **Never mount the heater in the vertical position.**

Breezy conditions must be considered when heating any patio. Windbreaks can be extremely effective in increasing comfort and reducing heating costs. Windbreaks must be designed in such a way as to allow the necessary fresh air and ventilation for proper heater operation (see ventilation of installation section).

Sunpak® heaters must always be operated in a location that allows uniform air pressure around the heater. If only part of the heater is located in a wind protected zone damage to the heater may occur. Time should be taken to observe how the wind will affect the heaters under local conditions.

**MINIMUM CLEARANCE FROM COMBUSTIBLE MUST BE MAINTAINED (see chart on page 6 & 7)**

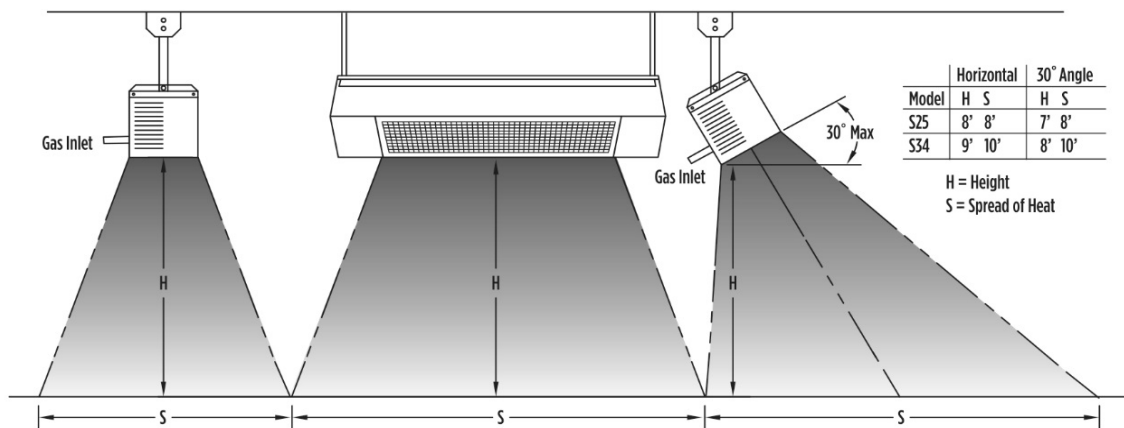

SUNPAK will raise the comfort level 5-10° Fahrenheit outdoors. The above coverage table was based on still breeze conditions. Under windy conditions more heat will be required. It is recommended that a windswept patio be designed with wind breaks to stabilize the patio environment. Wind breaks shall NOT interfere with the ventilation or combustion air requirements of the heater(s) and meet clearance for combustible requirements listing on page 6 & 7.

**WARNING:** Severe updrafts such as you might get on a raised terrace or roof top patio can cause damage to the heater.

**ANGLE MOUNTING:** Most applications of the SUNPAK® heater may be angle-mounted to a maximum of 30° to accommodate mounting the heaters around the edges of the patio. Note that the top clearance to combustibles increases when heater is tipped from the horizontal.

**NOTE:** Local codes may have special requirements regarding head clearance requirements. Some local codes require all portions of overhead radiant heaters to be located at least 8 feet above the floor.

### Sunpak® Infrared Heater Location

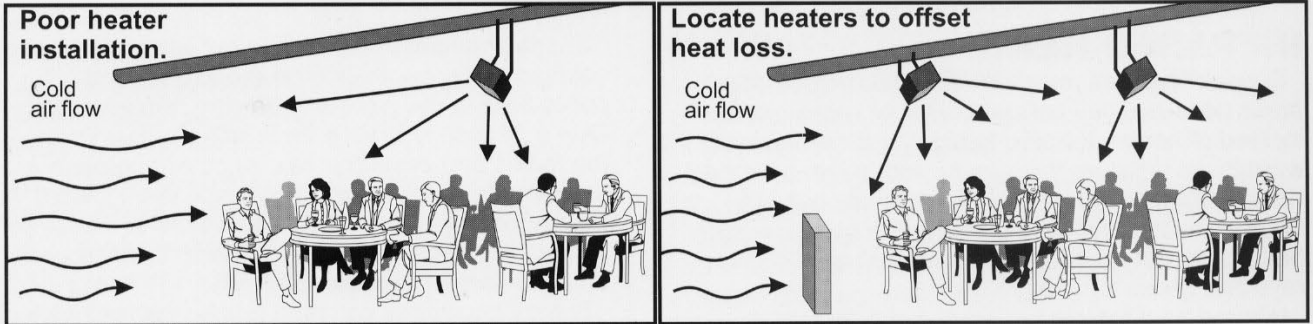

### Suggested Installation Configurations

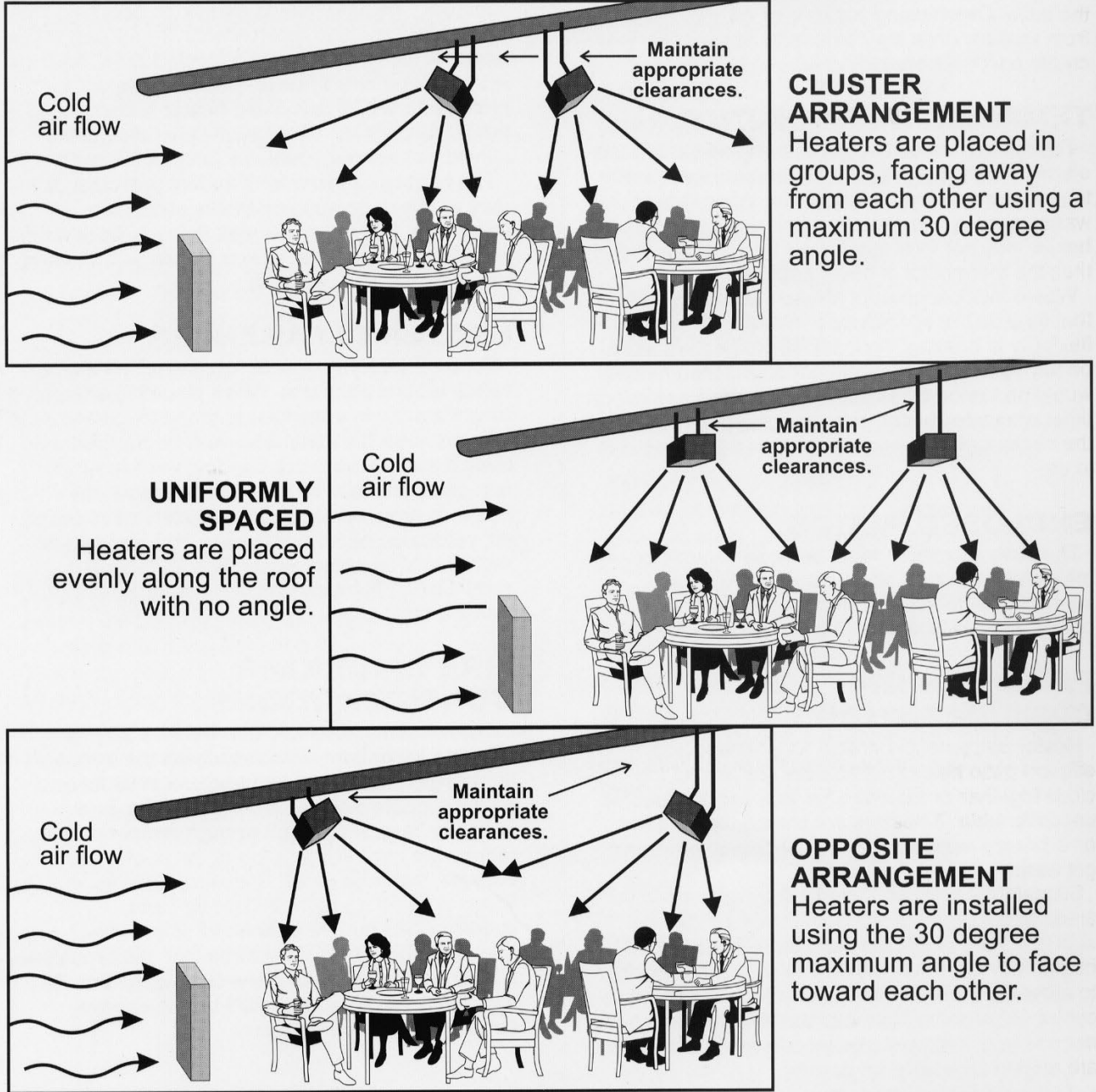

# SUNPAK® S25 & S34 INFRARED HEATERS

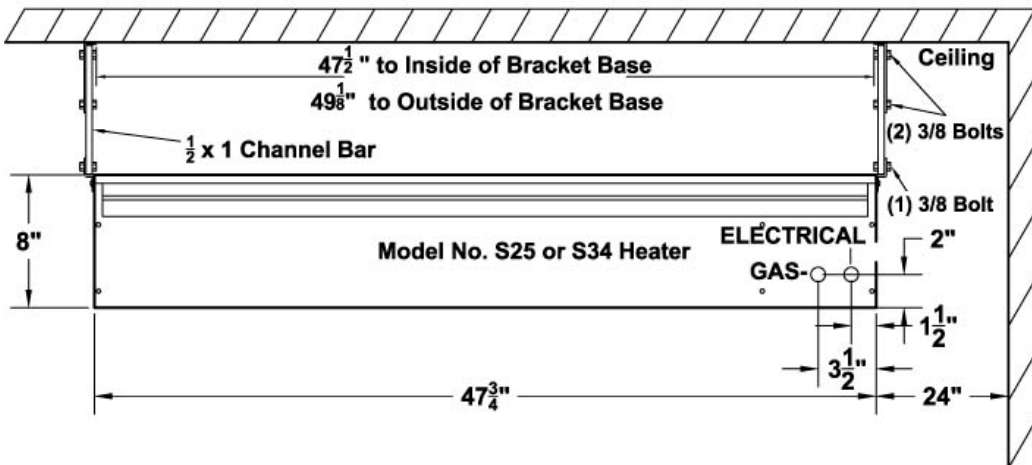
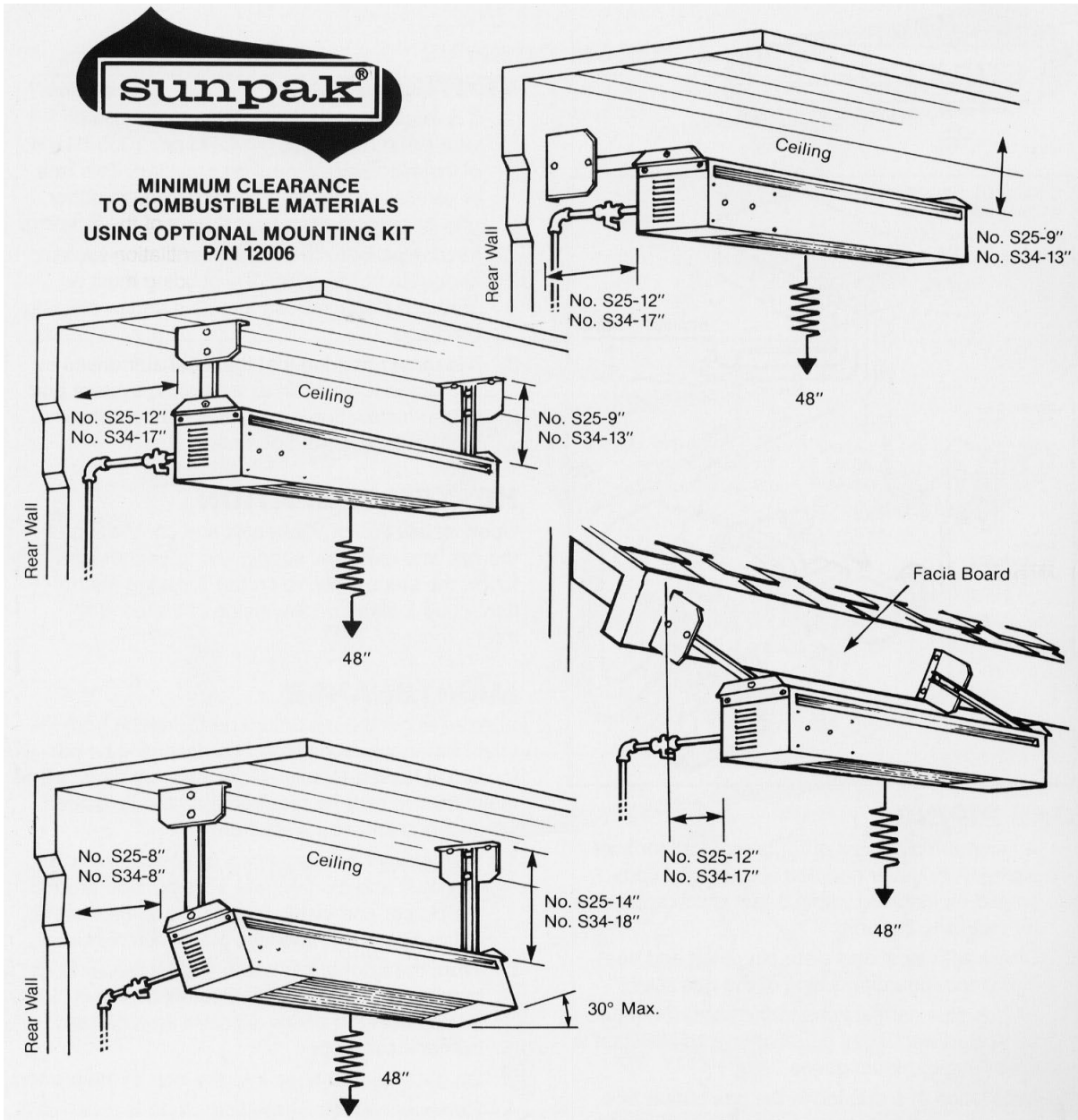

**Warning:** Heater must be level in the lengthwise direction.



## Installation/Service Instructions

### Receiving Equipment

On receipt of equipment it is suggested that a visual inspection be made for external damage to the carton. If the carton is damaged, a note should be made on the Bill of Lading when signing for the equipment. Remove the heater from the carton. **If there is damage, report the damage to the carrier immediately.**

### INSTALLATION INSTRUCTIONS

#### Important Notice

These instructions are intended for qualified personnel, specifically trained and experienced in the installation of this type of equipment and related system components. Some states or provinces require installation and service personnel to be licensed. If your state or province is such, be sure your contractor bears the appropriate license. Persons not qualified shall not attempt to fix this equipment nor attempt repairs.

**⚠ WARNING**

**Asphyxia, Explosion or Fire**

Improper installation, adjustment, alteration, service or maintenance may create a hazard resulting in asphyxiation, explosion or fire, or damage to the equipment.

#### Code Requirements

Installation must be in accordance with local codes, or in the absence of local codes, with the latest edition of the National Fuel Gas Code, ANSI Z224 and National Electrical Code ANSI/NFPA 70, and for Canada, the latest edition of CAN/CGA-B149.1 and B149.2 and Canadian Electrical Code, CSA C22.1 Part 1 and Part 2.

- Heaters to be installed in Aircraft hangars must be installed in accordance with American National Standards for Aircraft Hangars, ANSI/NFPA No. 409.
- Heaters to be installed in Public Garages must be installed in accordance with NFPA No. 88A, Standards for Parking Structures.
- Heaters must be installed so that minimum clearances marked on the heaters will be maintained from vehicles parked below the heater.
- Each heater must be electrically grounded in accordance with the National Electrical Code, ANSI/NFPA 70, when an external electrical source is utilized. In Canada, the CSA Canadian Electrical Code, C22.1 Part 1 applies.

### Gas Supply

The gas inlet supply pressure and manifold pressures required for each heater are listed below. For gas supply line pressures in excess of ½ PSI, consult with your gas service provider or the factory.

Gas Inlet Pressure	Nat Gas	Propane
Maximum Pressure	½ PSI	½ PSI
Minimum Pressure	6" W.C.	11" W.C.
Manifold Pressure	5" W.C.	10" W.C.

**It is critical that the gas piping system be adequately sized for all the gas appliances it serves.**

### Clearances

Each heater must be installed such that the following "Minimum Clearance to Combustible Materials" are maintained. Combustible materials include wood, compressed paper, plant fibers, plastic, Plexiglas® or other materials capable of being ignited and burned. Such materials shall be considered combustible even though flame-proofed, fire retardant treated or plastered. Additional clearance may be required for glass, painted surfaces, vinyl siding or other materials which may be damaged by radiant or convection heat.

Adequate space around each heater is required even when the materials surrounding the heater are non-combustible to provide adequate combustion air and ventilation of exhaust gases. Heaters should never be located in a ceiling recess or soffit.

The stated clearance to combustible materials represents a surface temperature of 90°F (32°C) above room temperature. Building materials with a low heat tolerance (such as plastic, vinyl siding, canvas, tri-ply, etc.) may be subject to degradation at lower temperatures. It is the installer's responsibility to assure that adjacent materials are not subject to degradation.

In locations used for storage of combustible materials, signs shall be posted to specify the maximum permissible stacking height to maintain required clearances from the heater to combustible materials.

**OPTIONAL MOUNTING KIT (#12006):** Optional Mounting Kit is included in some packages. Whether the mounting kit is used or not, minimum clearance from combustibles must be observed as follows:

**WARNING:** The clearances shown below are also applicable to vehicles parked below heaters.

Model	Input BTUH	Side In	Rear In	Ceiling In	Below In	Mtg. Angle
S25	25,000	24"	12"	9"	48"	HORIZ
S34	34,000	24"	17"	13"	48"	HORIZ
S25*	25,000	24"	8"	14"	48"	30° MAX
S34	34,000	24"	8"	18"	48"	30° MAX

Above clearances apply to Natural and Propane.

\*Model S25 for propane gas for use in horizontal position only.

## SUNPAK® S25 & S34 INFRARED HEATERS

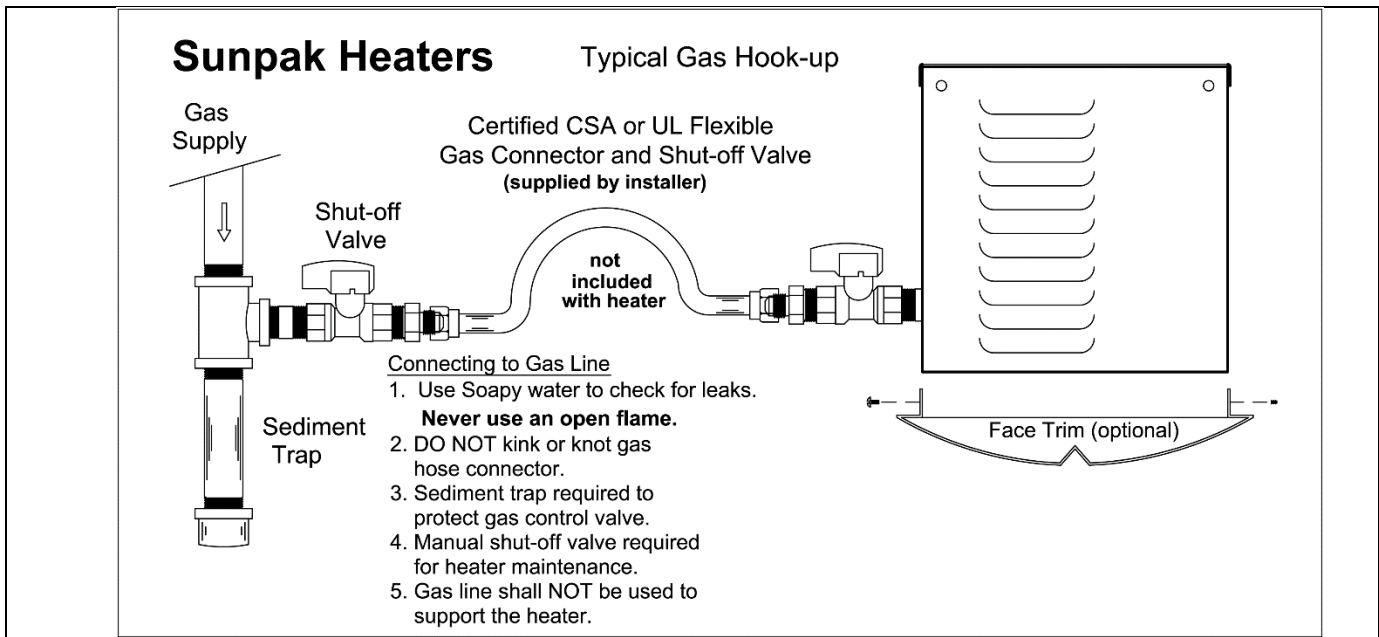

**WARNING**

**Suspension Hazard**

Mounting kits and hanging supports must be able to withstand a minimum working load of 75 lbs. (33 kg). Failure of the supports can result in death.

Local codes regarding head clearance requirement must be observed.

### Heater Mounting and Support

Heaters shall be mounted in a fixed position independent of gas and electrical supply line. Hangers and brackets shall be of noncombustible material.

Heaters subject to vibration shall be provided with vibration isolating hangers.

Suitable materials for hanging infrared heaters are steel pipe, steel channel, or fabricated hangers of at least 16-gauge material. Hanger and brackets must be secured with adequate anchor to a secure structure using good building practices. Additional bracing to protect against seismic forces may be required in seismically active areas. Never mount heaters to a moving object such as a trailer, motor home, boat, etc.

### Gas Piping

1. A minimum pipe size of  $\frac{1}{2}$ " is required for inlet piping. A  $\frac{1}{2}$ " lever handled gas shut-off valve should be installed within 6 feet of the appliance for servicing and as emergency shutoff to the unit.
2. Check with local and state plumbing and heating codes regarding sizing of gas lines.
3. All gas pipe connections to the heater(s) must be sealed with a gas pipe compound resistant to liquefied petroleum gases.
4. Installation of a drip leg or sediment trap in the gas supply line going to each heater is required to minimize the possibility of any loose scale or dirt within the gas supply line from entering the heater's control system.
5. When checking for gas leaks, do not use an open flame. Use a soap and water solution.
6. For gas supply line pressures in excess of  $\frac{1}{2}$  PSI, consult the factory or your local representative.
7. Installation of  $\frac{1}{8}$ " N.P.T. plugged tap accessible for test gage connections is required upstream of the gas supply connections to the heater.
8. Never use pipe sealing compound on brass to brass flared fittings.

### Electrical

1. Sunpak® Heaters (except TSR models) require a 24 VAC NEC Class 2 transformer. Each heater requires approximately 20VA or .08 amps. When multiple heaters are connected to one transformer, the transformer must be sized to accommodate the entire load. The transformer must never be located inside the heater.
2. Use at 18GA wire up to 50 feet from the heater. Use a minimum of 16GA wire for over 50 feet distance.
3. If any of the original wire supplied **inside** the appliance must be replaced, it must be replaced with wiring material having a temperature rating of at least 105 degrees Centigrade.



# SUNPAK® S25 & S34 INFRARED HEATERS

## Ventilation

1. It is required that areas above the heater be properly vented to allow for necessary combustion air and removal of combustion gases.
2. Heaters shall be provided with natural or mechanical means to supply and exhaust at least 4 cfm per 1,000 BTU per hour of heater input. Exhaust openings for removing the flue products shall be above the level of the heaters.
3. Heater ventilation must comply with state and local codes. **Never use heater in a fully enclosed area.**

## Fire Sprinklers

Fire Sprinklers must be located at an appropriate distance from each heater to avoid accidental activation of the sprinkler. Ethylene glycol or propylene glycol must never be used in fire sprinkler systems where heaters are present as these substances may become flammable when heated. A fire sprinkler professional must be consulted when heaters are installed where fire sprinklers are present to insure that heaters and the fire sprinkler system are properly integrated. Specific guidelines can be found in NFPA 13 regarding design and specifications for Fire Sprinkler Systems near heaters.

## Initial Start-Up Procedure

### (Read entire Procedure First)

1. Before turning ON your new heater make sure:
  - a. Heater is securely mounted and clearances from combustible materials have been observed (see Clearances – page 7);
  - b. Tip angle of heater does not exceed 30 degrees (see Correct Mounting – page 12);
  - c. Gas line is properly connected and there are no leaks (see Gas Piping – page 8);
  - d. Make sure 24 VAC is properly connected to the heater. Applying 120 VAC to the heater will damage the switch and other heater controls
2. Start Heater;
  - a. Turn ON manual gas valve.
  - b. Set switch to the high setting for the first 5 minutes.
  - c. If heater locks out, switch to OFF to RESET Heater and repeat start up sequence.
  - d. If the heater locks out several times there may still be air in the gas line.

**NOTE: Some white smoke may appear during or just after the initial start-up of the heater. White smoke will dissipate with proceeding use. This is normal due to some residual lubrication on a new heater**

## Regular Service and Maintenance

Over time, particularly during long periods of non-use, the heater can accumulate dirt and debris in and around the pilot and the burner. Routine maintenance should be performed at least once a year by a qualified service agency to insure the heater is operating properly. More frequent service may be required for heaters located near waterfronts. If local service is not available call your natural gas or propane supplier.

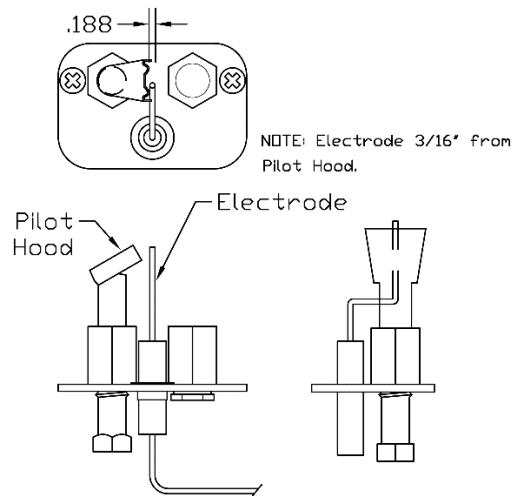

Sunpak Pilot and Electrode Position.

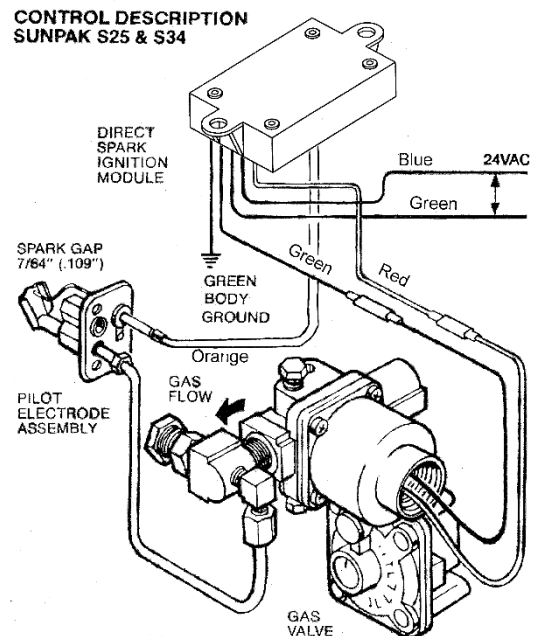

## SUNPAK® S25 & S34 INFRARED HEATERS

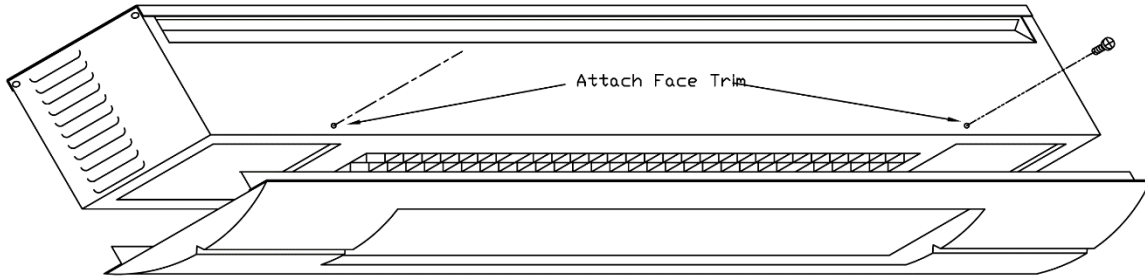

Optional Face Trim can be easily installed on all Sunpak models

You must remove the Sunpak Face Trim to connect power to the heater. The Sunpak Face Trim is secured with four (4) screws, two (2) located along each side of the heater.

### Wiring Diagram for Sunpak S25 & S34 Single Stage Hardwire Heater

- 1) 24 VAC / 20VA (.8 AMP required for each heater)
- 2) Electrical Polarity must be maintained when connecting multiple heaters
- 3) Never install the 24 VAC transformer inside the heater.

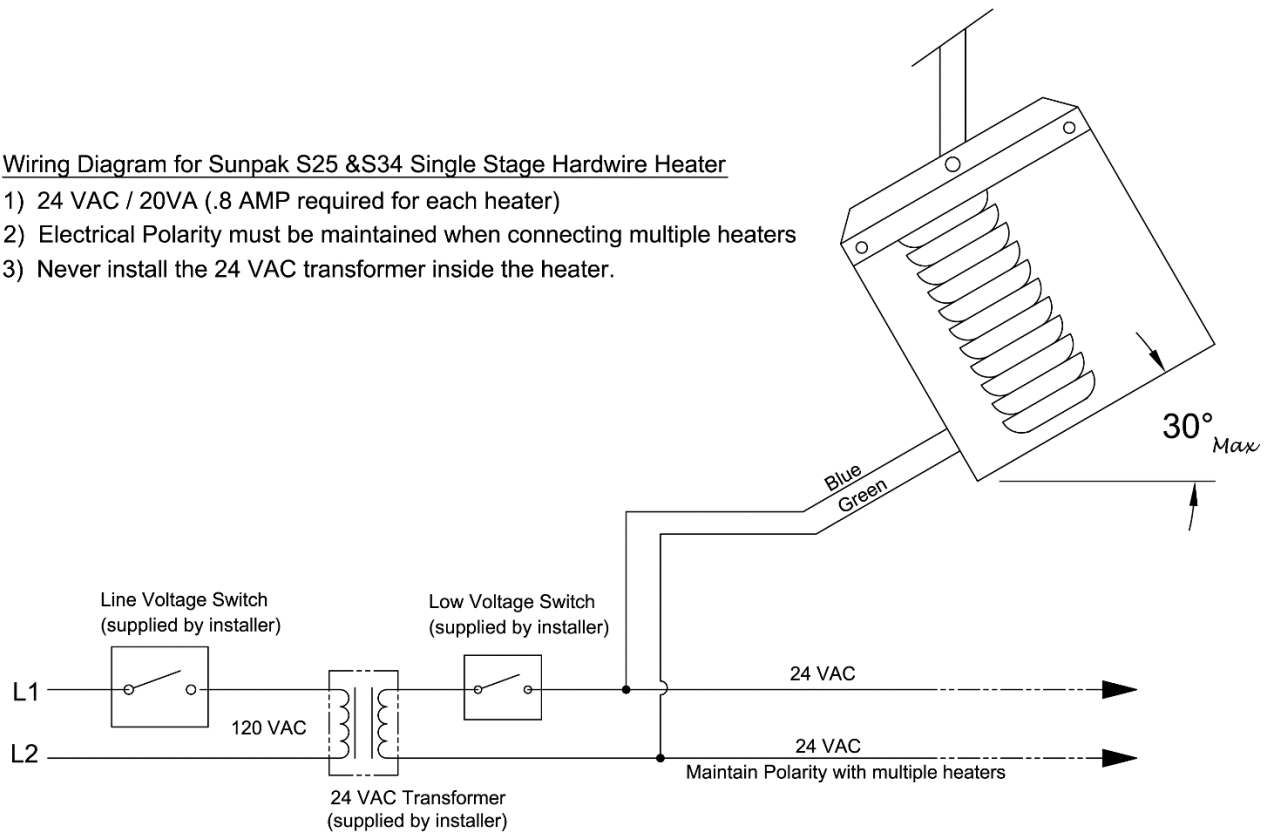

# SUNPAK® S25 & S34 INFRARED HEATERS

## MICRO 50N-24 Module

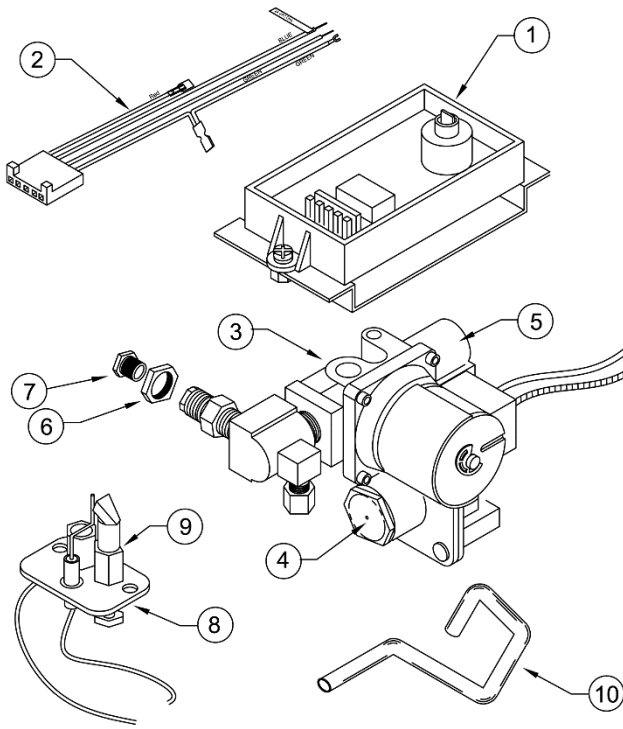
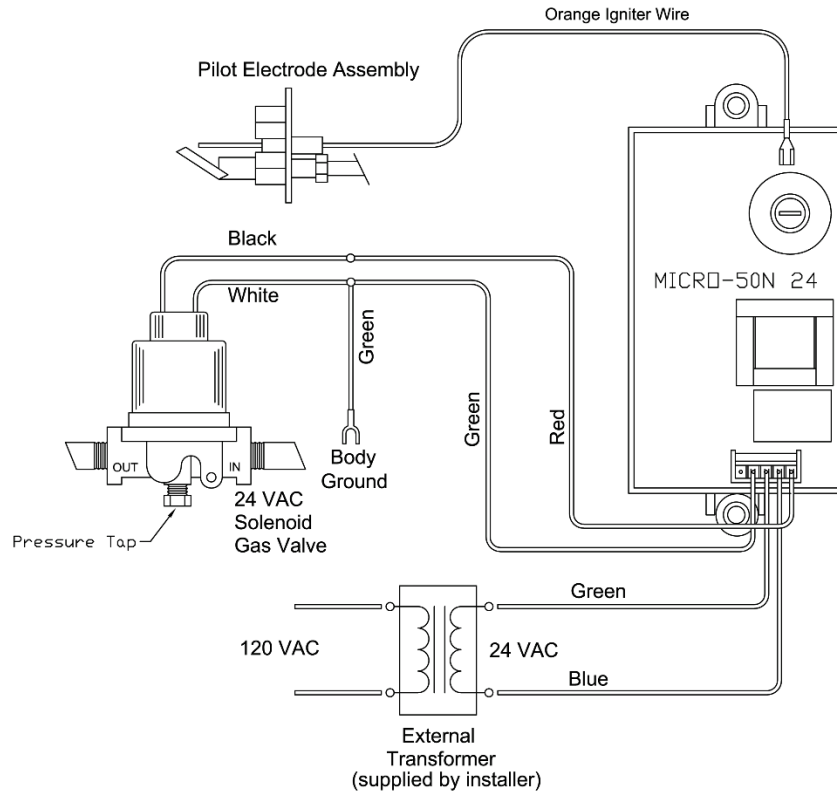

## Sunpak S25 & S34 Control Components

Item	Part No.	Description
1	120014	Kit, Micro Module - Std
2	90080-1	Harness, Micro Module
3	22021-1	Assy, Valve-Reg S25 Nat
	22021-2	Assy, Valve-Reg S34 Nat
	22021-3	Assy, Valve-Reg S25 LP
	22021-4	Assy, Valve-Reg S34 LP
4	90056-2	Reg, RV47CL-43 Conv
5	90054	Valve, 25-H91CG-12
6	80032	Lock Nut, 3/8
7	35001-44	Orifice, S25 - Nat
	35001-39	Orifice, S34 - Nat
	35001-53	Orifice, S25 LP
	35001-50	Orifice, S34 LP
8	22024	Assy, Pilot-Elect 2SH76 Nat
	22024-2	Assy, Pilot-Elect 2SH76 LP
9	90015	Pilot Orifice, Nat
	90016	Pilot Orifice, LP
10	80030	Tubing, Sunpak Pilot

## Sunpak Burner Replacement

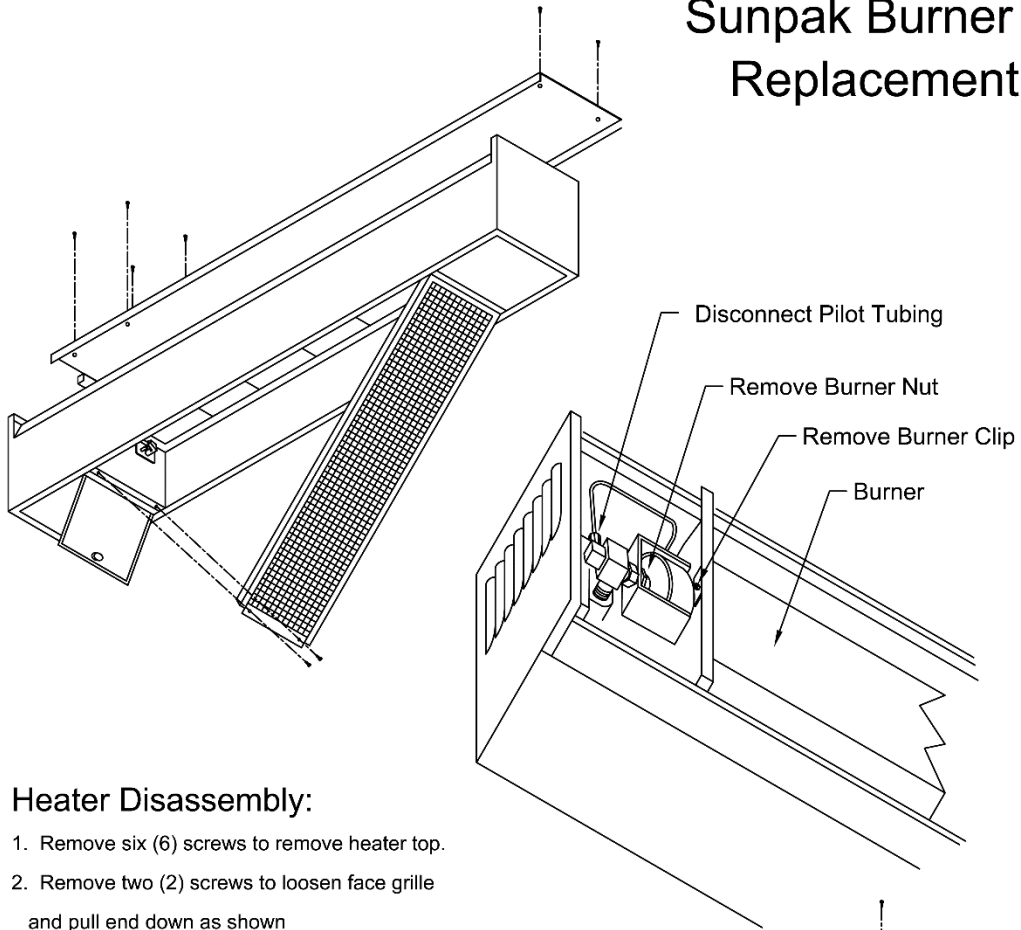

### Heater Disassembly:

1. Remove six (6) screws to remove heater top.
2. Remove two (2) screws to loosen face grille and pull end down as shown
3. Disconnect gas fitting from burner.
4. Remove burner clip
5. Remove two (2) screws from far end of burner
6. Carefully remove burner
7. Reverse process to install burner.
8. Run initial Start-up Procedure

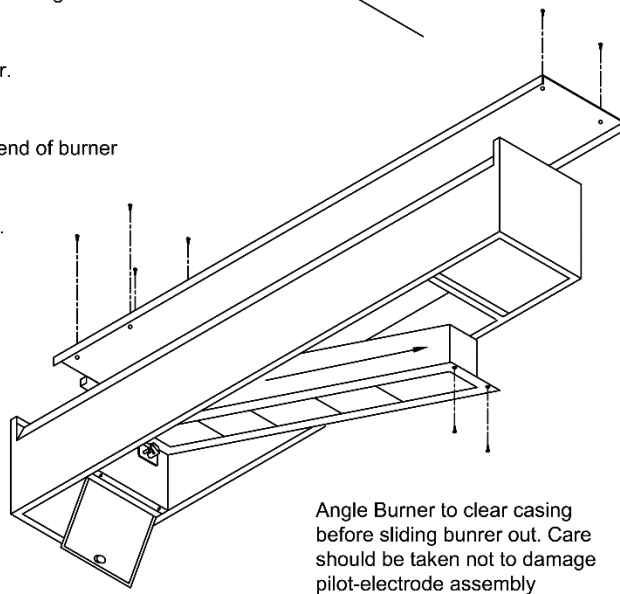

# SUNPAK® S25 & S34 INFRARED HEATERS

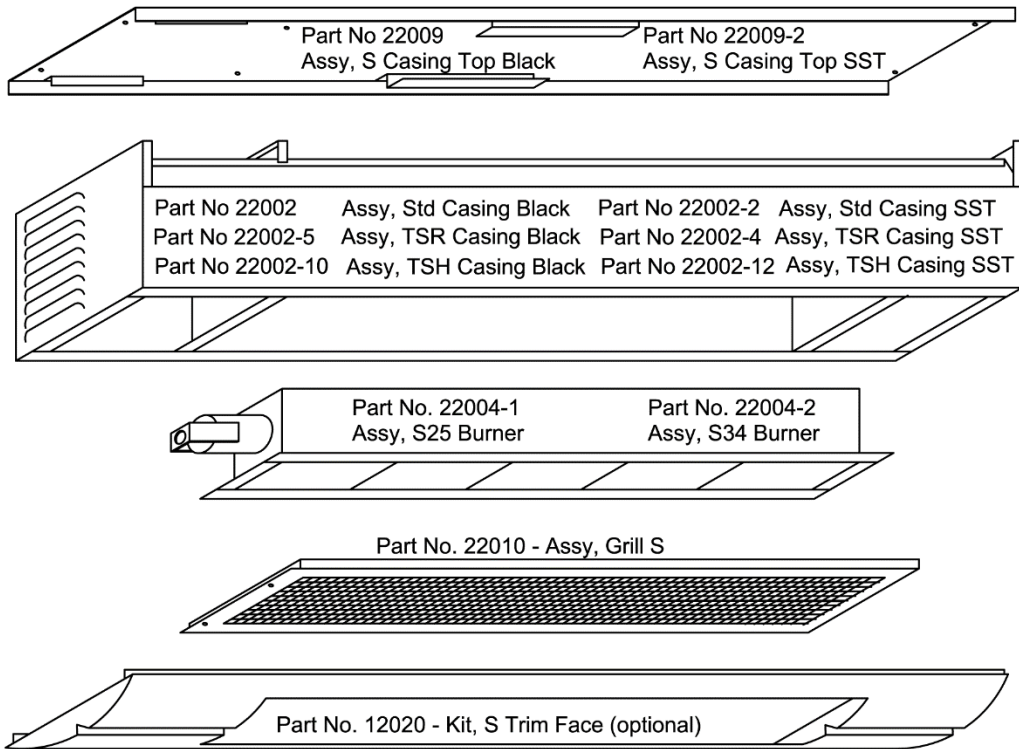

## Sunpak Heater must be mounted correctly ( Control End View )

### Angle Mounted

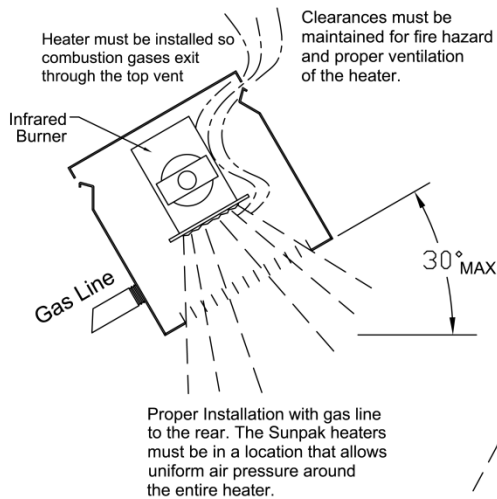

### Horizontal Mounted

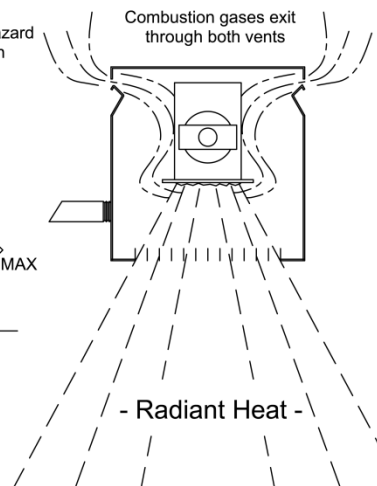

## Incorrect Mounting will cause damage to heater

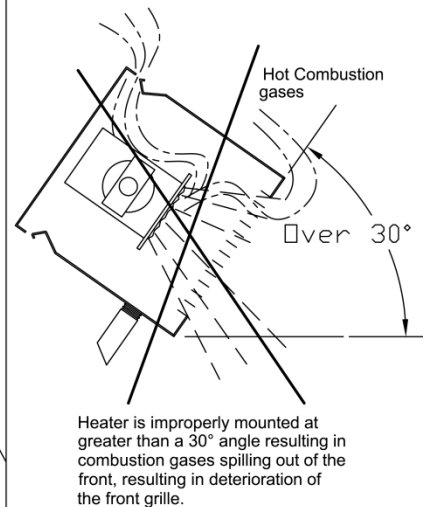

## Basic S25 & S34 Trouble Shooting

Problem	Possible Causes	How to Fix	References
No Spark to pilot	No power from transformer	<ul style="list-style-type: none"> <li>Replace Transformer</li> </ul>	
	No power to the heater	<ul style="list-style-type: none"> <li>Switch is On</li> <li>Verify wiring is properly connected to the heater module</li> </ul>	Electrical – Page 8 Basic Wiring – Page 10
Sparks, but does not ignite burner	No Gas to Heater	<ul style="list-style-type: none"> <li><b>Allow time for air to bleed from gas line on new installations</b></li> <li>Turn on manual gas valve</li> <li>Clean burner orifice</li> </ul>	Gas Piping – Page 8 Regular Service & Maintenance – Page 9
Heater lights, but turns off	Low Voltage	<ul style="list-style-type: none"> <li>Make sure you have 24 VAC to heater</li> </ul>	
	Loose or broken ground wire inside control compartment	<ul style="list-style-type: none"> <li>Secure ground wire to heater body</li> </ul>	Control System – Page 11
	Pilot Electrode	<ul style="list-style-type: none"> <li>Adjust pilot electrodes 3/16 from pilot hood.</li> <li>Replace Control Module</li> <li>Replace Pilot-Electrode Assembly</li> </ul>	Sunpak Pilot – Page 9 Control Components – Page 11
Not Enough Heat	Low Gas Pressure	<ul style="list-style-type: none"> <li>Verify required gas pressure to heater</li> </ul>	Gas Supply – Page 7 Gas Piping – Page 8
	Lack of Fresh Air to Heater	<ul style="list-style-type: none"> <li>Adjust tip angle to less than 30 degrees</li> <li>Add ventilation to patio above and below heater</li> </ul>	Ventilation – Page 9
	Dirty Orifice	<ul style="list-style-type: none"> <li>Clean orifice</li> </ul>	Regular Service & Maintenance – Page 9.
	Dirty Burner	<ul style="list-style-type: none"> <li>Use bottle brush to clear any cobwebs or debris from mixer tube of burner.</li> <li>Use compressed air (under 30 psi) to blow through ceramic (eye protection required)</li> </ul>	
	Poor Heater Coverage	<ul style="list-style-type: none"> <li>Review Heater Layout and Design</li> </ul>	Heater Layout & Design – Page 4
Deterioration of Front Grill	Tip Angle over 30 degrees	<ul style="list-style-type: none"> <li>Adjust Tip Angle to less than 30 Degrees</li> </ul>	Incorrect Mounting – Page 13
	Wind hitting heater from below	<ul style="list-style-type: none"> <li>Set up wind break to prevent strong breeze from hitting infrared burner face directly. Any wind break must not interfere with the safe operation of the heater.</li> <li>Heater must always be operated in an equal pressure environment</li> </ul>	Heater Layout & Design – Page 4
Burner Noise	Dirty Orifice	<ul style="list-style-type: none"> <li>Clean orifice thoroughly or replace if necessary</li> </ul>	Regular Service & Maintenance – Page 9
	Dirty Burner	<ul style="list-style-type: none"> <li>Use bottle brush to clean mixer tube of burner</li> <li>Use compressed air to clean ceramic burner ports (max 30 PSI) - eye protection required.</li> </ul>	
	Cracked Ceramics	<ul style="list-style-type: none"> <li>Replace infrared burner</li> </ul>	



## Limited Warranty

THIS WARRANTY IS APPLICABLE TO THE ORIGINAL OWNER ONLY, in accordance with the warranty terms and conditions specified below.

Infrared Dynamics (the warrantor) will furnish at our option the ORIGINAL OWNER, 1) a replacement Infrared Dynamics' heater or 2) a replacement part for any component part which fails before one year when for residential use. When the heater has been used for other than single family residential applications, the warranty shall be 90 days.

### **Service and Labor Responsibility**

UNDER THIS LIMITED WARRANTY, THE WARRANTOR WILL PROVIDE ONLY A REPLACEMENT HEATER OR PART THEREOF. THE OWNER IS RESPONSIBLE FOR ALL OTHER COSTS. Such costs may include, but are not limited to:

- a. Labor charges for service, removal, or reinstallation of the heater or part thereof.
- b. Shipping and delivery charges for forwarding the new heater or replacement part from the nearest distributor and returning the claimed defective heater or part to such distributor.
- c. All costs necessary or incidental for handling and administrative charges and for any materials and/or permits required for installation of the replacement heater or part.

### **LIMITATION ON IMPLIED WARRANTIES**

Implied warranties, including any warranty of merchantability imposed on the sale of this heater under state law are limited to one year duration for the heater or any of its parts. Some states do not allow limitations on how long an implied warranty lasts, so the above limitations may not apply to you.

### **CLAIMS PROCEDURE**

Any claim under this warranty should be initiated with the distributor, dealer, or seller who sold the heater, or with any other dealer handling the warrantor's products. If this is not practical, the owner should contact: Infrared Dynamics, 3830 Prospect Avenue, Yorba Linda, California 92886. Phone 1-888-317-5255 or visit our website: [www.infradyne.com](http://www.infradyne.com).